

Galvanised box fans

Technical data

Voltage	U	240/420	V
Phase		3	~
Frequency		60	Hz
Speed		570	RPM
Power consumption	P _e	1650	W
Nominal current	I	4.7/2.7	A
Maximum current	I	5.0/2.9	A
Capacitor		-	μF
Ambient temperature	T _{amb min/max}	-25...40	°C
Insulation Class		CL.F	
IP Class Fan		IP55	
Weight		73.6	kg

Fan details

Impeller blades	3
Impeller type	10
Impeller system	N
Impeller material	PG

Control options

Triac controller	No
Transformer	No
Frequency drive	No
Intelligent Fan Drive	No

Characteristics

0 Pa 45300 m³/h
 50 Pa 33600 m³/h

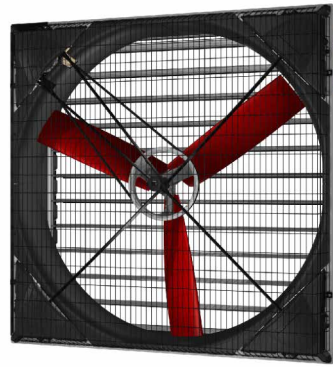
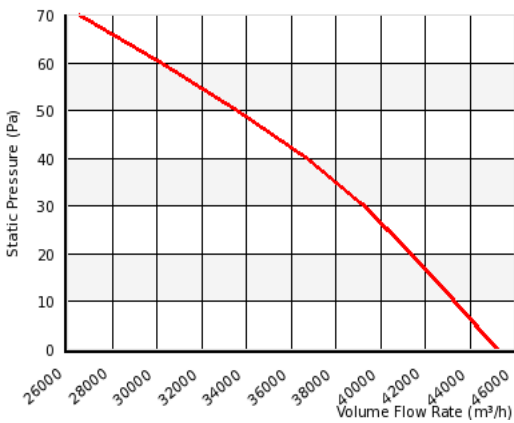

Please note: Picture may deviate from original product



No.

Wiring diagram - Fan

AF01 - CCW

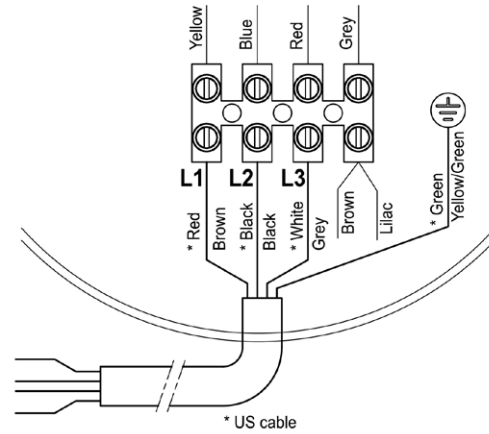

Dimensions

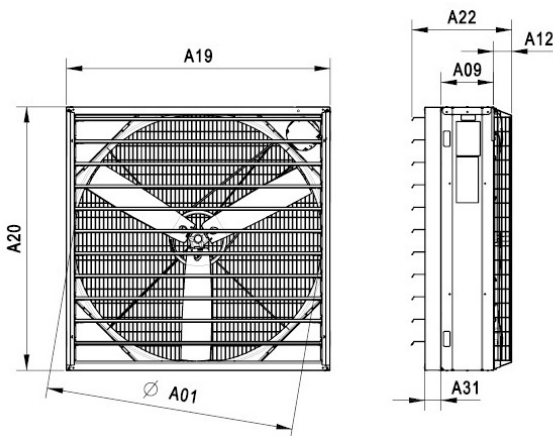

A01:	1284 mm
A09:	275 mm
A12:	96 mm
A19:	1382 mm
A20:	1382 mm
A22:	523 mm
A31:	85 mm